

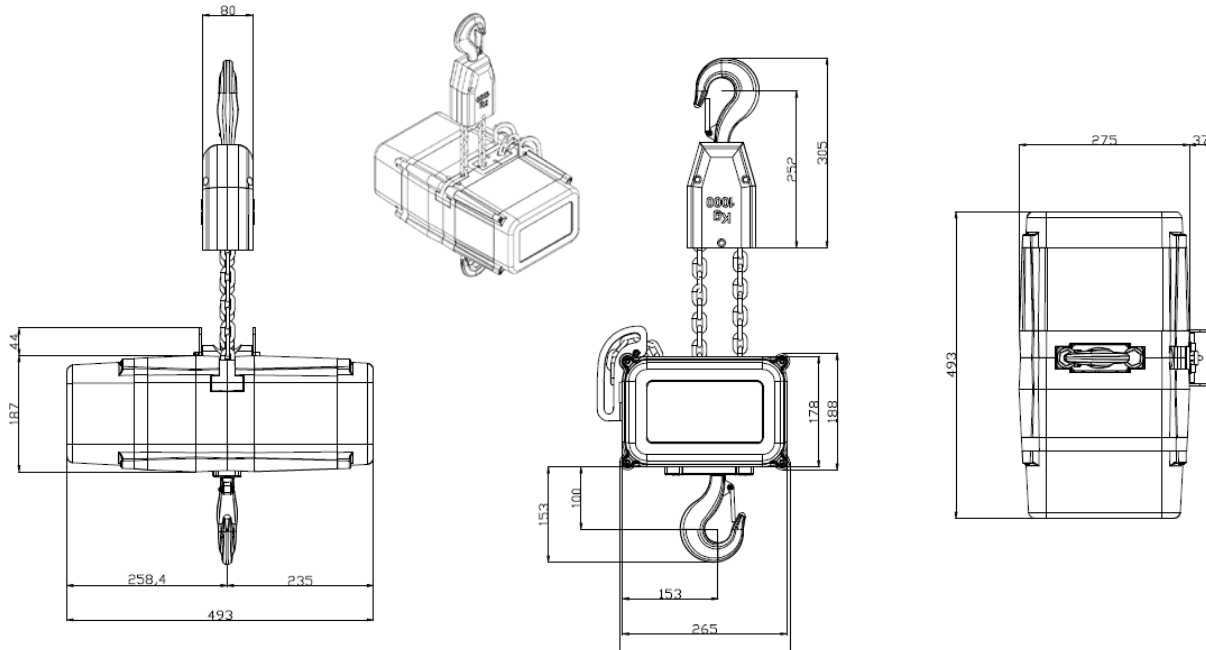

EXE-RISE CHAIN HOISTS

D8+ 1000kg-Direct control/double fall/double brake
TECHNICAL DATA SHEET

LT XRP100D8+



KEY FEATURES

Model:	D8+
Load capacity:	1000 kg
Lifting speed	@ 50Hz: 4m/min
3 ph Δ 230 VAC Y 400 VAC:	Δ 4.58 A – Y 2.64 A
Load wheel:	5 pockets
Clutch outside gear train	
Force limiting friction device	
Precision helical gearing	

HOIST SPECIFICATIONS:

Type of control:	Direct
Operating voltage:	230/400 V @ 50Hz
Motor power:	@ 50Hz: 1.5 kW
Revolution per minute:	1400
DC brake system:	2
Protection class:	IP55 DIN 40050
FEM class:	1Am
Connection cable:	L = 1 m
Type of connector:	CEE 16A – 3PH + G
Noise level:	67.5 db @ full load
Falls of chain:	2
Body weight:	42 kg
Upper swivel hook weight:	2.0 kg
Lower swivel hook:	2.0 kg

CHAIN SPECIFICATIONS:

Chain size:	7x22
Chain weight:	1.03 kg/m
Chain safety factor:	1:8
Grade of steel:	80
Surface:	Galvanic zinc coated

CHAIN BAG SPECIFICATIONS:

Chain bag size:	XL
Max chain length:	36 m
Colour:	Black

CUSTOMISABLE WITH:

Encoder
Load cell
Geared limit switches
Low voltage Control (st. 24VAC 50Hz)

Date of issue
17/09/2013

LITEC Italia S.p.A.
www.litectruss.com - info@litectruss.com