

HOIST SPECIFICATIONS:

- Voltage: 3 x 400V, 50Hz
- Motor Power: 0.73 kW
- Connection cable L=100cm / CEE 16A 3P+T 6H
- Protection class: IP65
- Lifting capacity: 1000kg
- Lifting speed: 4 m/min
- Lifting height: 18m (also available with 24m)
- Slip clutch before brake
- Body and cover black
- Equipped with black finish chain, black lower hook, chain stop
- Black swivel hook suspension
- Wearing plate
- Two hard handles
- Chain bag and bracket with carabiner
- Fast stop contact relay
- Weight (body only): 43.5 kg
- Weight (prepared) : 62.5 kg

CHAIN SPECIFICATIONS:

chain size: 7X22 mm
 chain weight/m: 1.05 kg
 chain safety factor: 6.28
 grade of steel: 80
 color: black

CHAIN BAG SPECIFICATIONS:

chain bag size: M [22 x 19 - h 43] cm
 max chain's length: 25 m
 color: black

OPTIONS:

- Low voltage conversion kit
- Geared limit switches plus e-stop

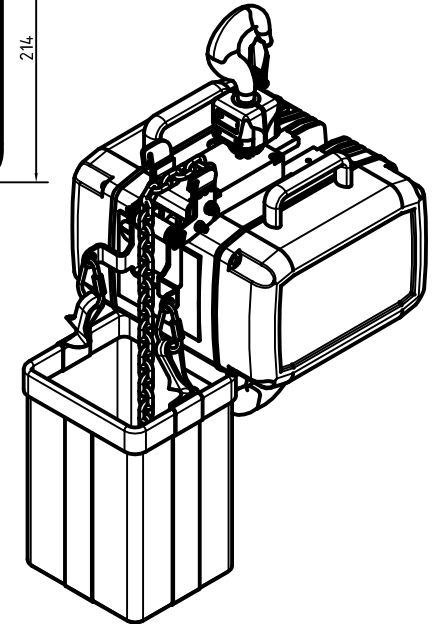
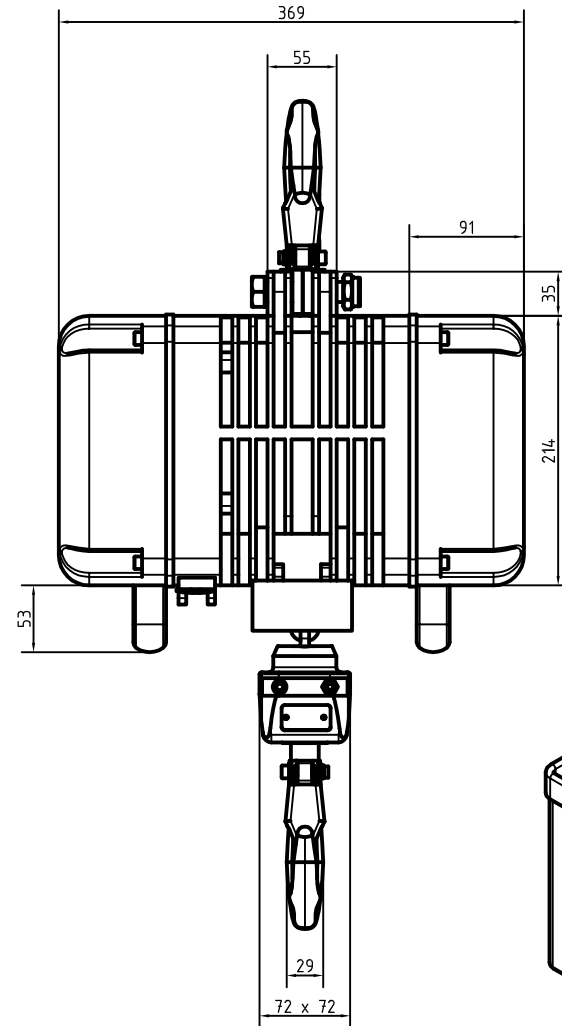
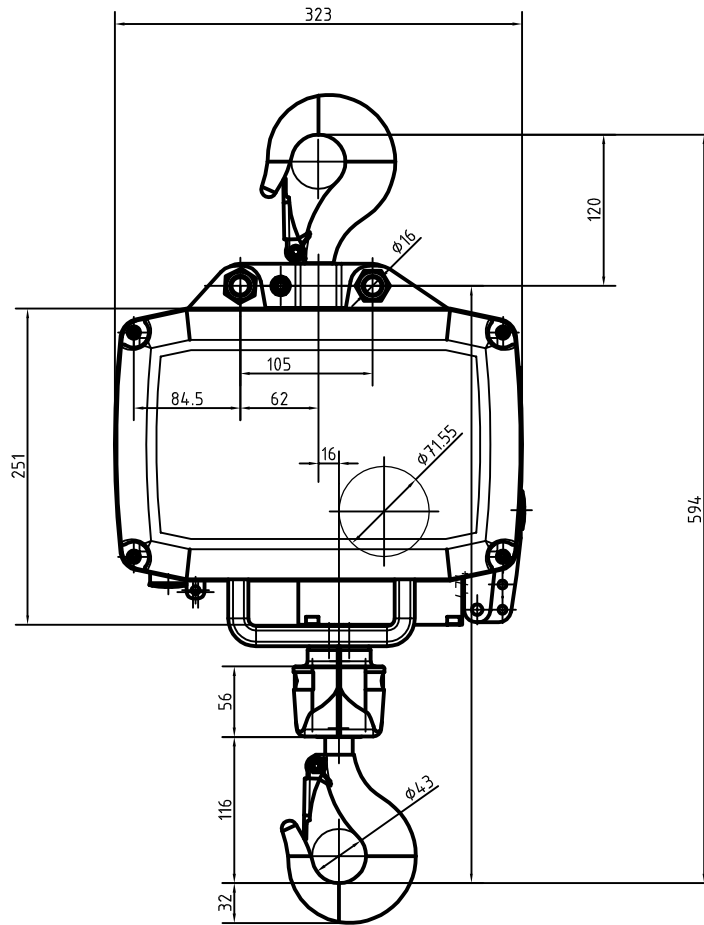

FEM classification	1Bm	1AM	2M	3M	Lifting speed	Motore power	3x400V 50Hz	Chain size	Chain safety factor	-Protection DIN 40050:	IP65	Special chain:	
Switchings /h	150	180	240	3M						-Insulation class	F	Garde:	DAT (8SS)
Duty factor %	25%	30%	40%	50%						-Fuse protection generally	10A	according to:	FEM 9.671
	kg	kg	kg	kg	m/min.	kW (1BM)	A (1Bm)	mm					
LT LH100D8	1000	800	320	250	4	0.73	2.7/3.0	7x22	6.28			LT LH100D8	SCALE 1:6