



# EXE-RISE CHAIN HOISTS

## D8 320kg-Direct control/single fall/double brake

### TECHNICAL DATA SHEET

LT XRP032DB

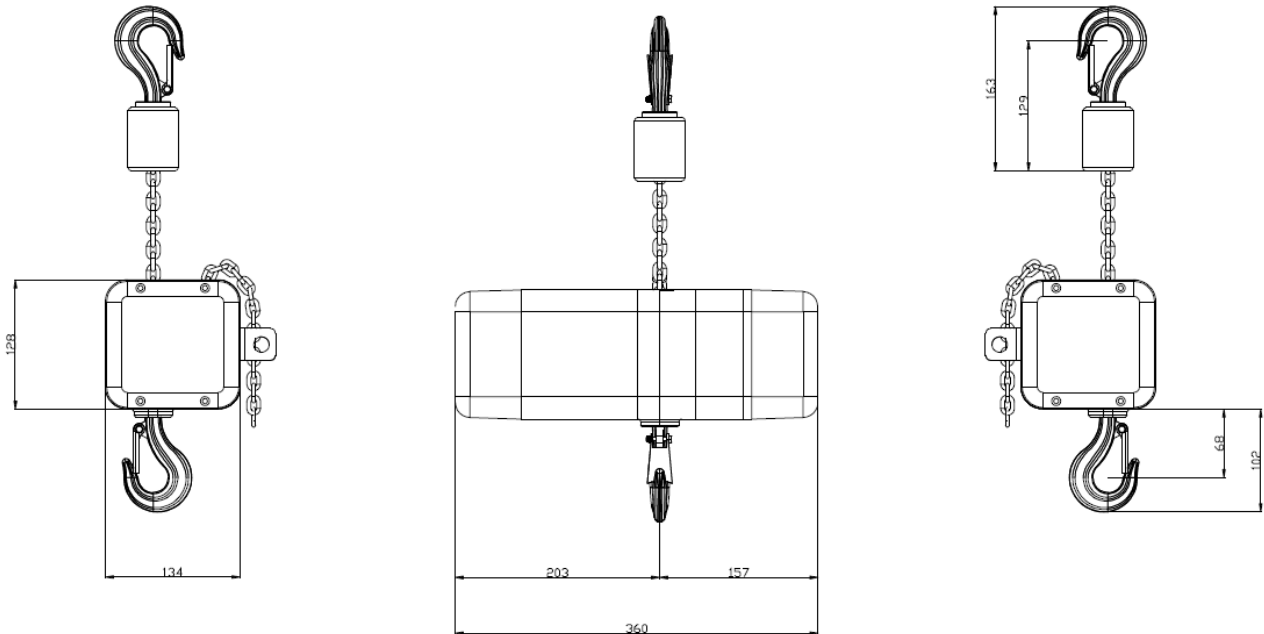

#### KEY FEATURES

Model:	D8
Load capacity:	320 kg
Lifting speed	@ 50Hz: 4m/min
3 ph $\Delta$ 230 VAC Y 400 VAC:	$\Delta$ 2.77 A – Y 1.60 A
Load wheel:	5 pockets
Clutch outside gear train	
Force limiting friction device	
Precision helical gearing	

#### HOIST SPECIFICATIONS:

Type of control:	Direct
Operating voltage:	230/400 V @ 50Hz
Motor power:	@ 50Hz: 0.5 kW
Revolution per minute:	1400
AC brake system:	2
Protection class:	IP55 DIN 40050
FEM class:	1Am
Connection cable:	L = 1 m
Type of connector:	CEE 16A – 3PH + G
Noise level:	67.5 db @ full load
Falls of chain:	1
Body weight:	17 kg
Upper swivel hook weight:	1.0 kg
Lower swivel hook:	1.0 kg

#### CHAIN SPECIFICATIONS:

Chain size:	4x12
Chain weight:	0.35 kg/m
Chain safety factor:	1:5
Grade of steel:	80
Surface:	Galvanic zinc coated

#### CHAIN BAG SPECIFICATIONS:

Chain bag size:	XS
Max chain length:	40 m
Colour:	Black

#### CUSTOMISABLE WITH:

Encoder	
Load cell	
Geared limit switches	
Low voltage Control (st. 24VAC 50Hz)	

Date of issue  
17/09/2013

LITEC Italia S.p.A.  
www.litectruss.com - info@litectruss.com