

HOIST SPECIFICATIONS:

- Voltage: 3 x 400V, 50Hz
- Motor Power: 1.53 kW
- Connection cable L=100cm / CEE 16A 3P+T 6H
- Protection class: IP65
- Lifting capacity: 2000kg
- Lifting speed: 4 m/min
- Lifting height: 24m (available also with 36m)
- Slip clutch before brake
- Body and cover black
- Equipped with black finish chain, black lower hook, chain stop
- Black swivel hook suspension
- Wearing plate
- Two hard handles
- Chain bag and bracket with carabiner
- Fast stop contact relay
- Weight (body only): 56 kg
- Weight (prepared) : 110 kg

CHAIN SPECIFICATIONS:

- chain size: 10X28 mm
- chain weight/m: 2.250 kg
- chain safety factor: 6.4
- grade of steel: 80
- color: black

CHAIN BAG SPECIFICATIONS:

- chain bag size: X [28 x 22 - h 63] cm
- max chain's length: 40 m
- color: black

OPTIONS:

- Low voltage conversion kit
- Geared limit switches plus e-stop

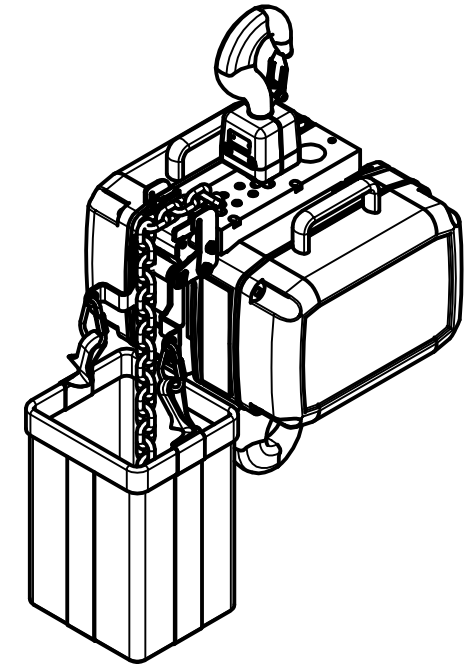
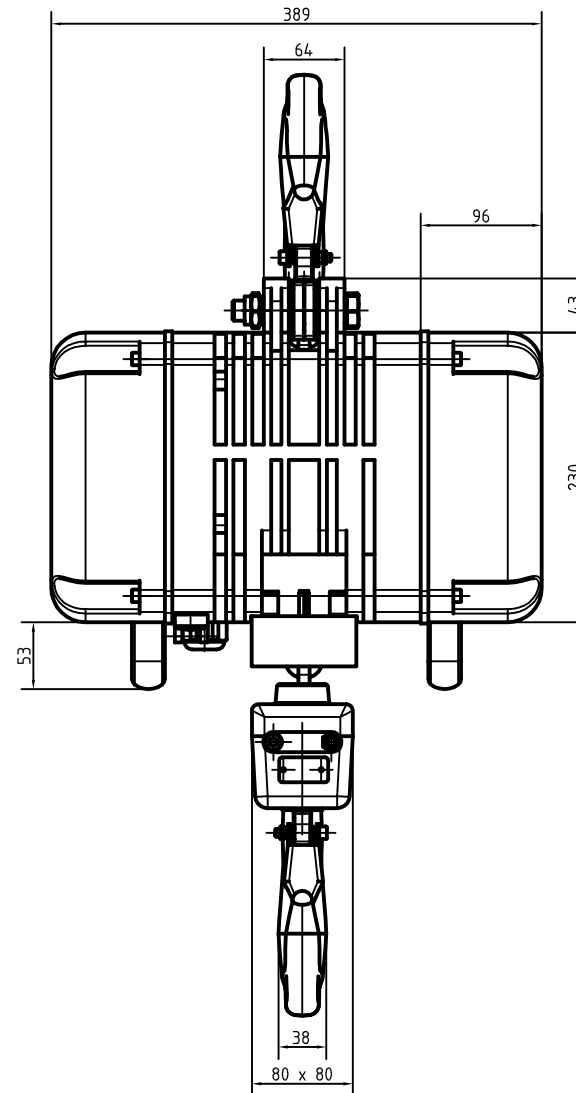
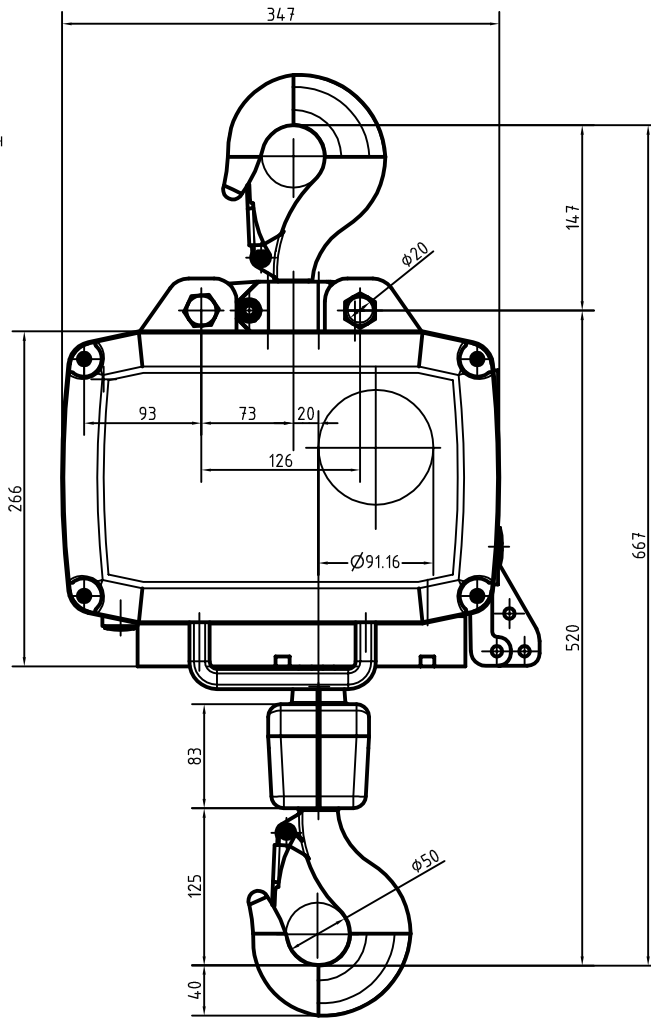

FEM classification	1Bm	1AM	2M	3M	Lifting speed	Motore power	3x400V 50Hz	Chain size	Chain safety factor
Switchings /h	150	180	240	3M					
Duty factor %	25%	30%	40%	50%	m/min.	kW (1Bm)	A (1Bm)	mm	6.4
	kg	kg	kg	kg					
LT LH200D8	2000	1600	1250	1000	4	1.53	4.8	10x28	6.4

-Protection DIN 40050:
-Insulation class
-Fuse protection generally
-Load hook DIN 1501

IP65
F
10A

Special chain:
Garde: DAT (8SS)
according to: FEM 9.671

LITEC HOIST

LT LH200D8

SCALE 1:6