

**HOIST SPECIFICATIONS:**

- Voltage: 3 x 400V, 50Hz
- Motor Power: 0,18 kW
- Connection cable L=100cm / CEE 16A 3P+T 6H
- Protection class: IP65
- Lifting capacity: 250kg
- Lifting speed: 4 m/min
- Lifting height: 16m (also available with 24m)
- Slip clutch before brake
- Body and cover black
- Equipped with black finish chain, black lower hook, chain stop
- Black swivel hook suspension
- Wearing plate
- Soft handles
- Chain bag and bracket with carabiner
- Fast stop contact relay
- Weight (body only): 21.5 kg
- Weight (prepared) : 27.5 kg

**CHAIN SPECIFICATIONS:**

chain size: 4X12,3 mm  
 chain weight/m: 0.35 kg  
 chain safety factor: 8,2  
 grade of steel: 80  
 color: black

**CHAIN BAG SPECIFICATIONS:**

chain bag size: S [22 x 19 - h 33] cm  
 max chain's length: 32 m  
 color: black

**OPTIONS:**

- Low voltage conversion kit
- Geared limit switches plus e-stop

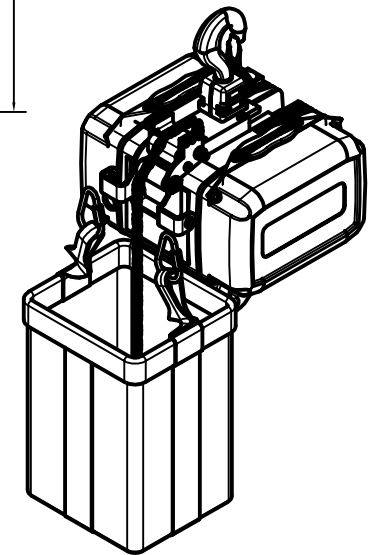
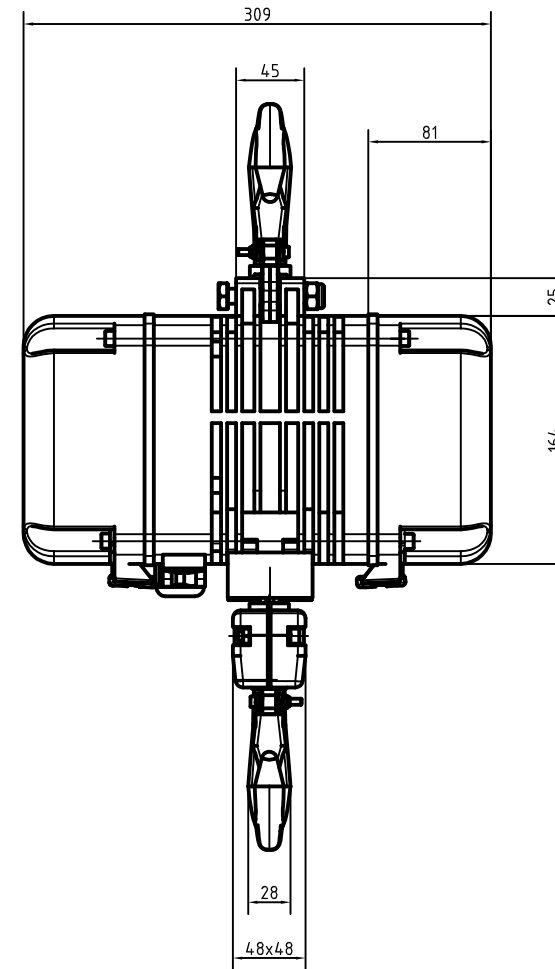
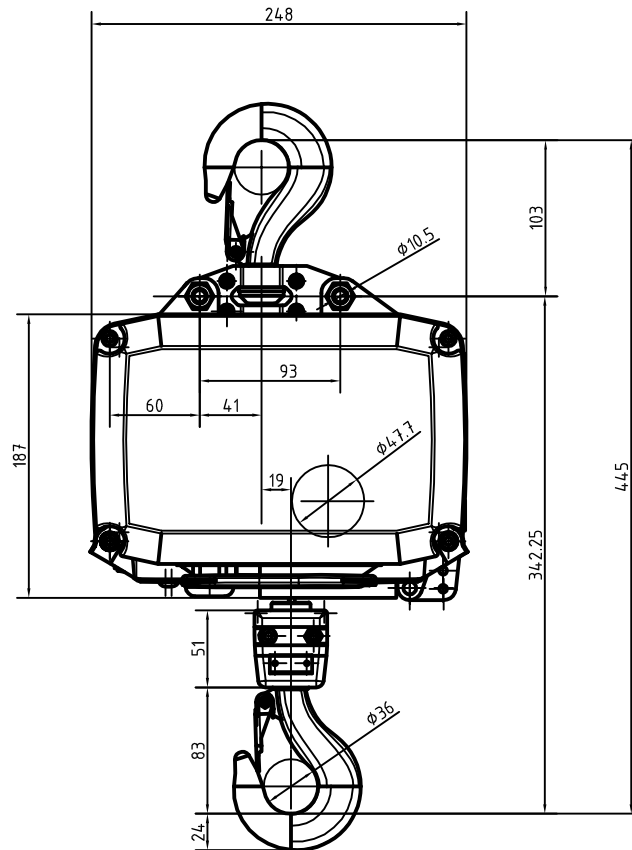

FEM classification	1Bm	1AM	2M	3M	Lifting speed	Motore power	3x400V 50Hz	Chain size	Chain safety factor	-Protection DIN 40050:	IP65	Special chain:				
										-Insulation class	F					
										-Fuse protection generally	10A					
Switchings /h	150	180	240	3M	m/min.	kW (1BM)	A (1Bm)	mm		-Load hook DIN 1501		Garde: DAT (8SS) according to: FEM 9.671				
Duty factor %	25%	30%	40%	50%												
	kg	kg	kg	kg												
LT LH025D8	250	200	160	125	4	0.18	2.7/3.0	4x12.3	8.2							

